



**KOLMEKS**  
EFFICIENT RELIABILITY

SERIES

L\_  
AL\_  
T  
AT  
AKN\_  
AS\_  
KL  
KN\_  
N\_

CENTRIFUGAL PUMPS

INSTRUCTION MANUAL

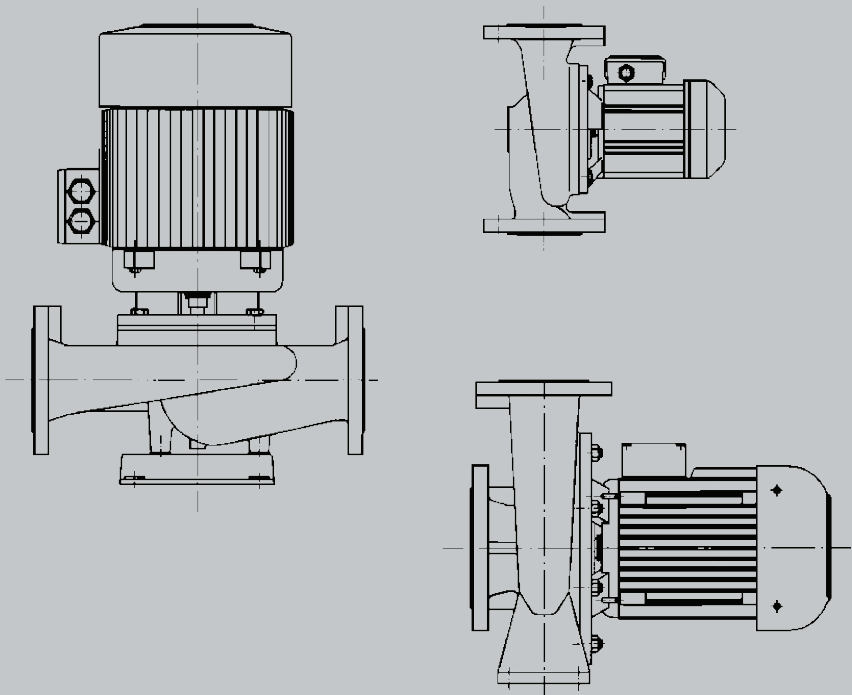

### TECHNICAL DATA

TYPE L_/T	r/min	kW	A (400V)	kg L	T	dB(A) 1m	
32A/4	1500	0.05	0.21	17	28	32	
	1500	0.08	0.28	17	28	32	
	/2	3000	0.25	0.70	18	30	52
	3000	0.65	1.80	21	36	53	
40A/4	1500	0.2	0.60	21	38	42	
	1500	0.37	1.15	25	46	45	
	/2	3000	1.1	2.80	27	50	55
	3000	1.5	3.30	33	62	60	
1032/4	1500	0.2	0.65	22			
	3000	1.1	2.8	27			
	3000	1.5	3.3	39			
50A/6	1000	0.11	0.50	24	46	38	
	1500	0.2	0.65	24	46	42	
	1500	0.25	0.82	24	47	42	
	1500	0.37	1.15	30	58	45	
50B/4	1500	0.2	0.65	24	46	42	
	1500	0.25	0.82	24	47	42	
	/2	3000	1.1	2.80	32	62	55
50C/2	3000	1.5	3.30	37	72	60	
	3000	2.2	4.70	43	78	62	
50S/4	1500	1.1	2.6	69	92	53	
	1500	1.5	3.5	71	96	54	
	1500	2.2	5.1	77	102	55	
	1500	3.0	6.60	83	108	56	
	/2	3000	5.5	11.00	105	130	74
	3000	7.5	15.00	113	138	74	
	3000	11.0	22.00	159	184	76	
	3000	15.0	30.50	164	189	76	
65A/6	1000	0.18	0.95	44	92	45	
	1000	0.37	1.20	44	92	45	
	/4	1500	0.2	0.75	37	76	45
	1500	0.37	1.00	37	76	45	
	1500	0.55	1.40	44	92	51	
	1500	0.75	2.00	44	92	51	
	1500	1.1	2.60	48	102	52	
	1500	1.5	3.50	52	107	53	
65B/6	1000	0.18	0.95	44	92	45	
	1000	0.37	1.20	44	92	45	
	/4	1500	0.2	0.75	37	76	45
	1500	0.37	1.0	37	76	45	
	1500	0.55	1.4	44	92	51	
	1500	0.75	2.0	44	92	51	
	1500	1.1	2.60	48	102	52	
	1500	1.5	3.30	52	107	62	
	/2	3000	2.2	4.70	52	108	62
	3000	3.0	6.40	58	120	65	
	3000	4.0	8.20	62	128	65	
	3000	5.5	11.00	86	177	74	
3000	7.5	15.00	94	193	74		
80A/6	1000	0.18	0.95	48	95	45	
	1000	0.37	1.20	48	95	45	
	1000	0.55	1.75	52	105	47	
	/4	1500	0.37	1.00	41	79	45
	1500	0.55	1.40	48	95	51	
	1500	0.75	2.00	48	95	51	
	1500	1.1	2.60	52	105	52	
	1500	1.5	3.50	56	110	53	
	/2	3000	2.2	4.70	56	111	62
	3000	3.0	6.40	62	123	65	
	3000	4.0	8.20	66	131	65	
	3000	5.5	11.00	90	180	74	
3000	7.5	15.00	98	196	74		
80S/4	1500	1.1	2.60	92	171	52	
	1500	1.5	3.50	96	179	54	
	1500	2.2	5.10	102	191	55	
	1500	3.0	6.60	108	203	55	
	1500	4.0	8.70	128	243	64	
	1500	5.5	11.90	138	263	64	
100S/4	1500	3.0	6.6	150	56	64	
	1500	4.0	8.70	170	64	64	
	1500	5.5	11.90	180	64	64	
	1500	7.5	15.7	195	65	65	
	1500	11.0	22.6	215	68	68	
	1500	15.0	31.0	230	69	69	
	/2	3000	15.0	30.5	200	74	74
	3000	18.5	34	245	74	74	
	3000						
	3000	22.0	38	275	76	76	

TYPE L_/T	r/min	kW	A (400V)	kg L	T	dB(A) 1m	
	3000	30	53	34578			
	3000	37	64	36580			
	3000	45	77.5	40580			
125S/4	1500	18.5	34.00375		70		
	1500	22.0	42.00390		71		
	1500	30.0	55.00450		72		
	1500	37.0	69.00510		74		
	1500	45.0	81.00550		78		
TYPE AL_/AT	r/min	kW	A (400V)	kg AL	AT	dB(A) 1m	
106S/6	1000	0.18	0.95	44	84	45	
	1500	0.2	0.75	37	70	45	
	1500	0.37	1.0	37	70	45	
	1500	0.55	1.4	44	84	51	
	1500	0.75	2.0	44	84	51	
	1500	1.1	2.60	48	92	52	
	/2	3000	1.5	3.30	51	92	62
	3000	2.2	4.70	52	100	62	
	3000	3.0	6.40	58	112	65	
	3000	4.0	8.20	62	120	65	
3000	5.5	11.00	86	168	74		
3000	7.5	15.00	94	184	74		
1066/6	1000	0.37	1.20	44	84	45	
	1500	0.2	0.75	37	70	45	
	1500	0.37	1.00	37	70	45	
	1500	0.55	1.40	44	84	51	
	1500	0.75	2.00	44	84	51	
	1500	1.1	2.60	48	92	52	
1081/6	1000	0.18	0.95	51	113	45	
	1000	0.37	1.20	51	113	45	
	1000	0.55	1.75	54	119	47	
	/4	1500	0.37	1.00	44	99	45
	1500	0.55	1.40	51	113	51	
	1500	0.75	2.00	51	113	51	
1082/6	1500	1.1	2.60	54	119	52	
	1500	1.5	3.50	58	127	53	
	/2	3000	2.2	4.70	57	106	62
	3000	3	6.40	63	118	65	
	3000	4	8.20	67	126	65	
	3000	5.5	11.00	91	174	74	
3000	7.5	15.00	99	190	74		
1082/6	1000	0.37	1.20	64	127	45	
	1000	0.55	1.75	67	133	47	
	1000	0.75	2.40	69	141	48	
	1000	1.1	3.50	69	141	48	
	/4	1500	1.1	3.50	69	141	53
	1500	1.5	3.50	71	141	54	
	1500	2.2	5.10	77	153	55	
	1500	3	6.50	83	165	55	
1102/6	1000	0.37	1.20	59	111	45	
	1000	0.55	1.75	62	117	47	
	1000	0.75	2.40	66	125	48	
	/4	1500	0.55	1.40	59	111	51
	1500	0.75	2.00	59	111	51	
	1500	1.1	2.60	62	117	53	
	1500	1.5	3.50	66	125	54	
	1500	2.2	5.10	72	137	55	
	/2	3000	4.0	8.20	75	141	65
	3000	5.5	11.00	99	189	74	
	3000	7.5	15.00	109	209	74	
	1106/4	1500	3.0	6.60	145	280	56
1500		4.0	8.70	165	320	64	
1500		5.5	11.90	175	330	64	
1500		7.5	15.70	190	360	65	
/2		3000	15	30.50	195	370	74
3000		18.5	33.00	240	460	74	
3000		22	40.00	270	520	76	
3000		30	52.00	340	660	78	
3000		37	67.00	360	700	80	
3000		3.0	6.60	150	310	56	
1129/4	1500	4.0	8.70	170	350	64	
	1500	5.5	11.90	180	365	64	
	1500	7.5	15.70	195	395	65	
	1500	11	22.60	215	435	68	
	1500	15	31.00	230	465	69	
	/2	3000	18.5	33.00	250	505	74
	3000	22	40.00	280	565	76	
	3000	30	52.00	350	705	78	
	3000	37	67.00	370	745	80	

TYPE AL_/AT	r/min	kW	A (400V)	kg AL_ AT	dB(A) 1m	
1154/6	1000	5.5	12.70	220	415	64
/4	1500	4.0	8.7	195	375	64
	1500	5.5	11.90	205	385	64
	1500	7.5	15.70	220	415	65
	1500	11	22.60	240	455	68
	1500	15	31.00	255	485	69
	1500	18.5	34.00	270	515	70
1155/2	3000	30.0	52.00	375		78
	3000	37.0	67.00	395		80
	3000	45.0	83.00	435		80
	3000	55.0	98.00	465		82
1202/6	1000	5.5	12.70	295	580	64
	1000	7.5	17	345	680	68
	1000	11	22	345	680	68
1202/4	1500	11	22.60	315	620	68
	1500	15	31.00	330	650	69
	1500	18.5	34.00	365	720	70
	1500	22	42.00	380	750	71
	1500	30	55.00	460	910	72
	1500	37	69.00	500	990	72
/2	3000	45	84.00	500		88
	3000	55	103	570		90
	3000	75	139	700		93
1250/6	1000	11	22.00	385	720	68
	1000	15	30.50	430	810	69
	1000	18.5	35.50	505	960	70
	1000	22	43.5	515	980	71
	1000	30	55.00	580	1110	72
/4	1500	37	69.00	610	1170	74
	1500	45	82.00	650	1250	78
	1500	55	100	730	1410	82
	1500	75	134	870	1690	82
	1500	90	160	950	1850	82
1300/4	1500	110	195	1250		83
	1500	130	231	1350		83
	1500	160	279	1500		84
TYPE AKN_	r/min	kW	A (400V)	kg	dB(A) 1m	
100/6	1000	0.75	2.40	71		48
	1000	1.1	3.50	71		49
/4	1500	1.5	3.50	73		54
	1500	2.2	5.10	79		55
	1500	3	6.60	84		55
/2	3000	7.5	15.00	114		74
	3000	11	22.00	160		74
	3000	15	30.50	165		74
	3000	18.5	32	240		74
	3000	22	38	240		76
127/4	1500	4.0	8.70	126		64
	1500	5.5	11.90	133		64
/2	3000	11	22.00	190		74
	3000	15	30.50	195		74
	3000	18.5	32	270		74
	3000	22	38	270		76
TYPE AS_/KN_	r/min	kW	A (400V)	kg	dB(A) 1m	
32 B	1500	0.55	1.40	38		51
	1500	0.75	2.00	38		51
H	3000	1.5	3.30	43		62
	3000	2.2	4.70	46		62
	3000	3	6.40	53		65
	3000	4	8.20	57		65
50 B	1500	0.55	1.40	41		51
	1500	0.75	2.00	41		51
	1500	1.1	2.60	46		52
50 H	3000	4	8.20	60		65
	3000	5.5	11.00	83		74
	3000	7.5	15.00	90		74
65/4	1500	2.2	5.10	64		55
	1500	3	6.50	69		55
/2	3000	5.5	11.00	93		74
	3000	7.5	15.00	100		74
	3000	11	22.00	150		76
	3000	15	30.50	155		76
TYPE KL	r/min	kW	A (400V)	kg	dB(A) 1m	
32-160/2	3000	1.5	3.30	39		62
	3000	2.2	4.70	41		62
32-200/2	3000	3	6.40	49		65
	3000	4	8.20	53		65
	3000	5.5	11.00	68		74
40-160/2	3000	3	6.40	53		65
	3000	4	8.20	57		65
	3000	5.5	11.00	72		74
40-200/2	3000	7.5	15.00	80		74
	3000	11	22.00	125		76
50-160/2	3000	5.5	11.00	75		74
	3000	7.5	15.00	84		74
50-200/2	3000	11	22.00	130		76
TYPE N_	r/min	kW	A (400V)	kg	dB(A) 1m	
32-200A/4	1500	0.55	1.40	51		51
	1500	0.75	2.00	51		51
/2	3000	3.0	6.40	65		65
	3000	4.0	8.20	65		65
	3000	5.5	11.00	74		74
32-250B/4	1500	1.1	2.60	52		52
	1500	1.5	3.50	52		52
	1500	2.2	5.10	55		55
/2	3000	7.5	15.00	74		74
	3000	11	22.00	76		76
	3000	15	30.50	76		76
40-200A/4	1500	0.55	1.40	51		51
	1500	0.75	2.00	51		51
	1500	1.1	2.60	52		52
/2	3000	4.0	8.20	65		65
	3000	5.5	11.00	74		74
	3000	11	22.00	76		76
40-250A/4	1500	1.1	2.60	52		52
	1500	1.5	3.50	52		52
	1500	2.2	5.10	55		55
/2	3000	11	22.00	76		76
	3000	15	30.50	76		76
50-250A/4	1500	2.2	5.10	55		55
	1500	3.0	6.60	55		55
	1500	4.0	8.70	64		64
/2	3000	15	30.50	76		76
	3000	18.5	33.00	77		77
	3000	22	40.00	77		77
50-315B/4	1500	5.5	11.90	64		64
	1500	7.5	15.7	65		65
65-200A/4	1500	1.5	3.50	54		54
	1500	2.2	5.10	55		55
	1500	3.0	6.60	55		55
/2	3000	15	30.50	76		76
	3000	18.5	33.00	77		77
	3000	22	40.00	77		77
65-315B/4	1500	5.5	11.90	64		64
	1500	7.5	15.70	65		65
	1500	11	22.60	68		68
	1500	15	31.00	69		69
80-315B/4	1500	11	11.90	68		68
	1500	15	31.00	69		69
	1500	18.5	34.00	70		70
	1500	22	42.00	71		71
100-315B/4	1500	11	22.60	68		68
	1500	15	31.00	69		69
	1500	18.5	34.00	70		70
	1500	22	42.00	71		71

## DESIGN AND FUNCTION

The pump and motor constitute a unit, where the rotating parts of both the pump and the motor are on the same shaft (mono-block construction). The motor is of a dry construction and its bearings work at the same time as bearings for the whole pump.

Motor: Fully-enclosed A.C. motor  
Protection form IP 54  
IP 55  
- 4 kW and up (1000, 1500 r/min)  
- 5,5 kW and up (3000 r/min)  
Insulating class F  
Max. temperature of environment + 45 °C

## SAFETY SYMBOLS



Sign of danger to persons



Sign of voltage danger

**ATTN**

Sign of danger to safe operation of the pump and/or protection of the pump itself

## FIELDS AND LIMITS OF APPLICATION AND USE

**L, AL** Clean, thin, non-aggressive liquids  
**AT, T** - circulating water for heating and cooling  
**AKN** - water-glycol mixtures, recommendation:  
**AS** propylenglycol max. 40 %  
**KN** Nominal pressure 10 bar  
**N** Max. temperature + 120°C (+ 100°C with plastic impeller)

**LH** Clean, thin, non-aggressive liquids  
**ALH** - like AL-serie pumps, but also for higher temperature liquids  
Nominal pressure 16 bar  
Max. temperature + 120°C normal  
+ 150°C with special seal  
+ 180 °C with quench and special seal

**LP** Clean, thin, slightly aggressive liquids  
**ALP** - domestic water, oxygen rich waters  
**ASP**  
**KNP** Nominal pressure 10 bar  
**NP** Max. temperature + 120°C

**KL** Aggressive, thin, no particles containing liquids  
- in addition to above mentioned liquids various acids, salts, oxidizing and chemically active organic fluids  
Nominal pressure 10 bar  
Max. temperature + 120°C

**LS** Aggressive, thin, not bigger solid particles containing liquids  
**ALS** - in addition to above mentioned liquids various acids, salts, oxidizing and chemically active organic fluids  
Nominal pressure 16 bar  
Max. temperature + 120 - 180 °C depending on seal construction/materials used

**ATTN** Suitability of materials and seals for pumped liquid shall be always checked between purchaser and supplier.

The nominal pressure and the max. temperature of pumped liquid are stamped on the pump data plate.



Never use the pump in any other application or conditions without manufacturer's acceptance. In the case of damage there may be danger to persons by having poisoning, burns, wounds etc. depending on the pumped liquid and it's temperature and pressure. The pump surface temperature may cause danger depending on the working conditions.

## HANDLING, TRANSPORT AND STORAGE OF THE PUMPS

The heavier pumps are provided with lifting links.

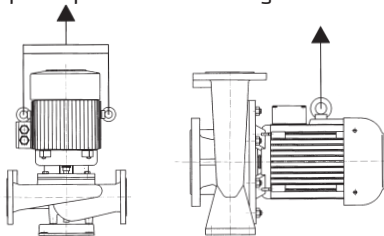

Pumps shall be stored in a dry and cool place protected from dust.

In the case of longer storage time it is recommended to rotate the pump manually f.ex. from the motor fan at least once a month. When the pump serves as a stand-by or is stopped for longer time for some reason, it is necessary to start it for a while after two weeks stoppage.

## INSTALLATION AND START-UP

When installing the pump pay attention to the following:

- space enough for service and inspection of the pump
- possibility to use lifting mechanism if needed
- shut-off valves on the both sides of the pump

The smaller pumps (below 15 kW) can be mounted without the foot.

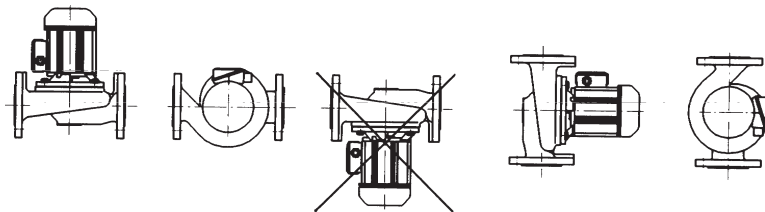

The heavier pumps should be fastened to a foundation of concrete which is isolated from the floor f.ex. with 20 mm thick gum or cork plate(s). The weight of the concrete foundation must be about 1.5 times the weight of the pump.

The position of the motor unit and the terminal box can be changed by removing the motor unit from the pump housing and setting it to the desired position (not in ALH- and LH-serie).

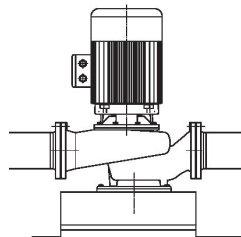



All electrical work shall be carried out by an electrician approved by the power supplier.

Check, that the voltage on the pump data plate corresponds to the mains voltage.  
Standard connections:

Smaller motors (below 4 kW)

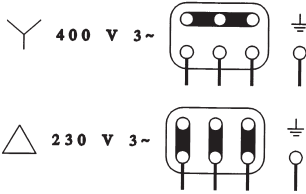

Bigger motors

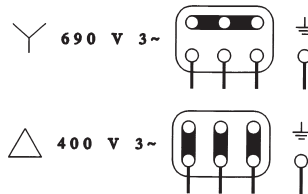

**ATTN** A starter must always be used and should be an ordinary motor protection breaker. Make sure that the overload protection is set no higher than the rated current specified on the pump data plate. Connect the two twin pump (AT-and T-serie) motors to separate fuse groups.

Check the direction of rotation of the pump during start-up and always after re-connection. The flow direction is indicated by an arrow on the pump housing. Depending on pump type the twin pump motors may rotate to opposite directions.

Before starting the pump fill and vent the system. Make sure that the pump rotates freely by rotating it manually f.ex. from the motor fan.

**ATTN** Never start or let the pump run dry.

After starting make sure that there is no extra noise coming from the pump and that no leakages appear.

**ATTN** An inverter can be used for regulating the speed of rotation of the pump. An inverter must be adjusted to prevent the overload of the motor. The current switch-off is to be adjusted according to rated current. **Note.** The use of over 50 Hz frequency may cause the overload of the motor.

In the twin pump installation both units should operate alternately. An appropriate duty period is about two weeks.

## MAINTENANCE AND REPAIR

The pump doesn't need any regular servicing.

As a shaft seal is used an adjustment free mechanical seal. It is a wearing part which has to be replaced if it starts to leak. Note that few drops leakage per hour can be quite normal especially when coolants (f.ex. glycol) are pumped.

Shaft seal, type constructions:

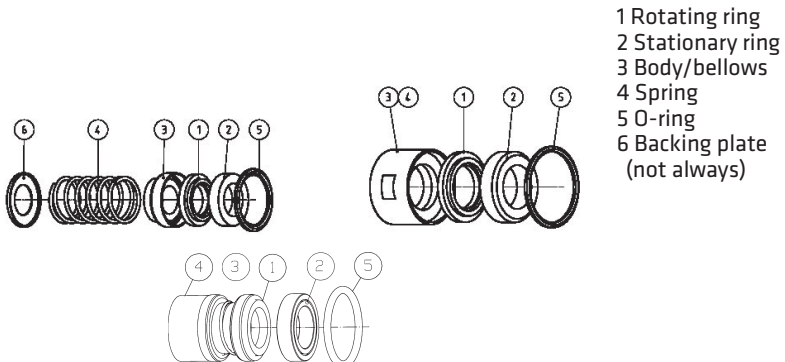

The motor is equipped with ball bearings which are lubricated for life and therefore do not need any service. In the case of any motor malfunction it is recommended to replace the whole motor unit.

In the twin pump installation it is possible to substitute the damaged unit by a blind cap (to be ordered separately). The other unit can be driven then normally.

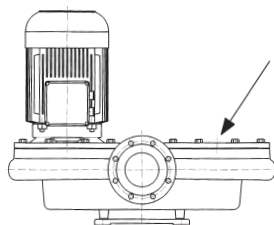

WHEN ORDERING SPARE PARTS, PLEASE SPECIFY THE TYPE IDENTIFICATION, SERIAL NUMBER, THE SIZE OF THE IMPELLER, THE MOTOR TYPE AND POWER AND THE POSITION NUMBER OF THE SPARE PART.

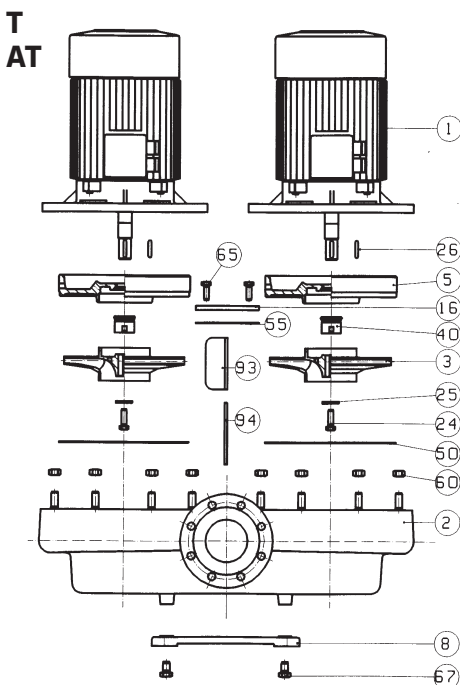
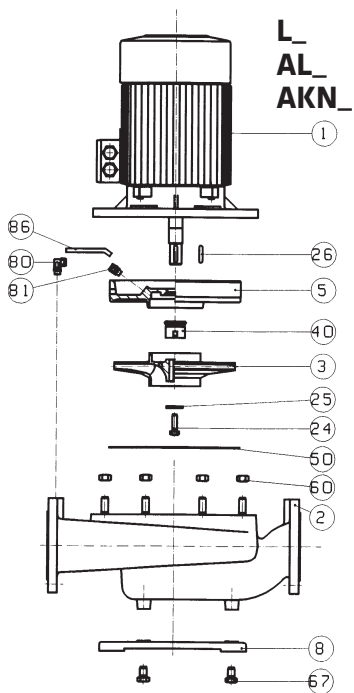

POS.NO.	DESCRIPTION	POS.NO.	DESCRIPTION
1	ELECTRICAL MOTOR	50	O-RING (GASKET)
2	PUMP HOUSING	55	GASKET (T- and AT-serie)
3	IMPELLER	60	SCREW OR NUT
5	SEALING FLANGE	65	SCREW (T- and AT-serie)
8	FOOT (not always)	67	SCREW
16	COVER (T- and AT-serie)	80	PIPE UNION (LH- and ALH-serie)
24	SCREW OR NUR	81	PIPE UNION (LH- and ALH-serie)
25	WASHER	86	COOLING PIPE (LH- and ALH-serie)
26	KEY	93	FLAP (T- and AT-serie)
40	SHAFT SEAL	94	CYLINDICAL PIN(T- and AT-serie)

AS\_  
KL\_  
KN\_  
N\_

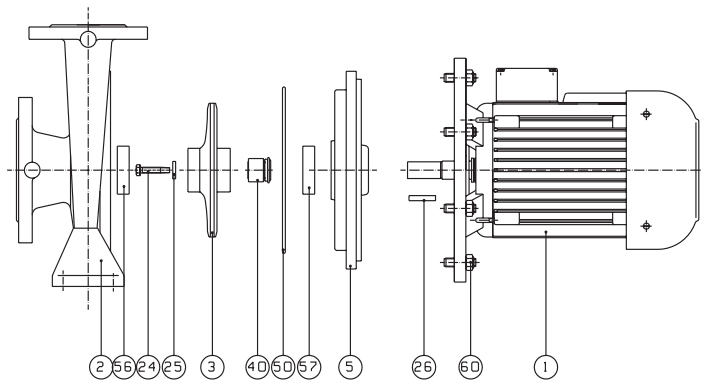

POS.NO.	DESCRIPTION	POS.NO.	DESCRIPTION
1	ELECTRICAL MOTOR	26	KEY
2	PUMP HOUSING	40	SHAFT SEAL
3	IMPELLER	50	O-RING
5	SEALING FLANGE	56-57	WEARING RING (N_-SERIE)
24	SCREW	60	SCREW OR NUT
25	WASHER		

EC-DECLARATION OF CONFORMITY

We, KOLMEKS LTD P.O.Box 27 FI-14201 Turenki

Declare under our sole responsibility that the centrifugal pumps

- |              |                          |             |                          |
|--------------|--------------------------|-------------|--------------------------|
| L_ - SERIE   | <input type="checkbox"/> | AS_ - SERIE | <input type="checkbox"/> |
| AL_ - SERIE  | <input type="checkbox"/> | KN_ - SERIE | <input type="checkbox"/> |
| T - SERIE    | <input type="checkbox"/> | KL_ - SERIE | <input type="checkbox"/> |
| AT - SERIE   | <input type="checkbox"/> | N_ - SERIE  | <input type="checkbox"/> |
| AKN_ - SERIE | <input type="checkbox"/> |             |                          |

Serie / serial number \_\_\_\_\_

to which this declaration relates, are in conformity with the

- Machinery Directive 2006/42/EC
  - EMC-directive 2004/108/EC
  - Low voltage directive 2006/95/EC
  - Standard EN 809:1998+A1:2009
- Pumps and pump units for liquids. Common safety requirements.

Turenki 04.01.2010

Kimmo Issakainen  
Managing Director

Responsible of technical file

Kolmeks Ltd, P.O. Box 27, FI-14201 TURENKI, FINLAND  
Product Development Manager

**KOLMEKS LTD**

DISTRIBUTOR:

P.O. Box 27 FI-14201 Turenki  
Tel. +358 20 7521 31  
Fax. +358 20 7521 200